

Automotive Lighting Solution with IS32LT3146 and IS32LT3147



The newly released IS32LT3146 and IS32LT3147 LED drivers further expand Lumissil's portfolio of automotive lighting solutions. In this article, we will review the features and applications for these Lumissil products. First, we will examine the common features followed by features specific to each device.

FEATURES COMMON TO IS32LT3146 AND IS32LT3147

Both drivers provide 6-channels of current sources; each channel adjustable from 10mA to 75mA via an appropriate valued resistor at R_{ISET} input pin. Channels could be connected in parallel for increased current drive capacity up to a maximum of 450mA per device. These drivers are AEC-Q100 qualified, operate over temperature range of -40°C to 150°C and comes in thermally enhanced 6.5x4.4mm eTSSOP-20 package. Both drivers have a wide input voltage range of 5V to 40V to accommodate automobile battery voltage range and spikes. Both devices have a low headroom V_{HR} (see Figure 2) voltage and low quiescent current for low power consumption. Both products were designed with additional features to ease Automotive Lighting products system design such as thermal shunt to offload thermal stress away from the driver, comprehensive fault detection and reporting for added system reliability, current slew rate control to optimize EMI and thermal roll-off to ensure device lifespan reliability.

As illustrated in Figure 1, each driver has 2 input supply pins (VINA and VINB) where a thermal shunt resistor R_{SHUNT} is connected to 1 supply pin (VINB) and the remaining supply pin (VINA) is connected to the power supply (vehicle's battery) directly. This permits current flow through VINA path when V_{BAT} voltage is low and at higher V_{BAT} voltage more current will flow through the VINB path where R_{SHUNT} dissipates excess heat; keeping the driver at acceptable temperature.

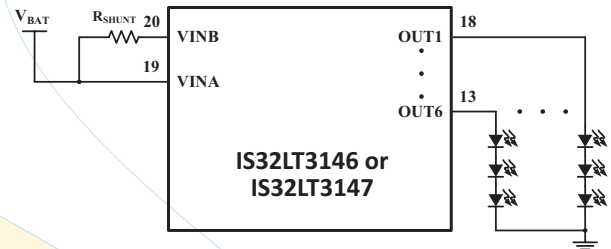

FIGURE 1 - THERMAL SHUNT

In Figure 2, when V_{BAT} voltage is between (V_{HR}+V_{STRING}) to V_{TR}, R_{SHUNT} keeps driver power dissipation reasonably low and only when V_{BAT} voltage exceeds V_{TR} does the power dissipation increases linearly. Hence, selection of an appropriate R_{SHUNT} resistor value will keep operation within the "Power Shunt Area" to avoid driver over-heating concerns.

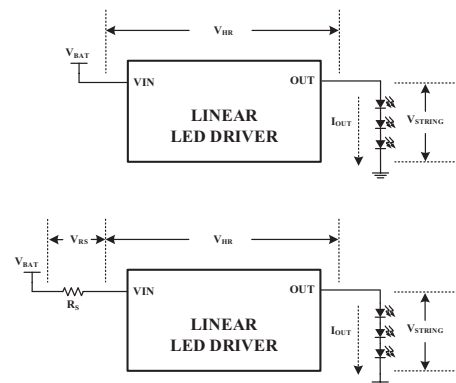
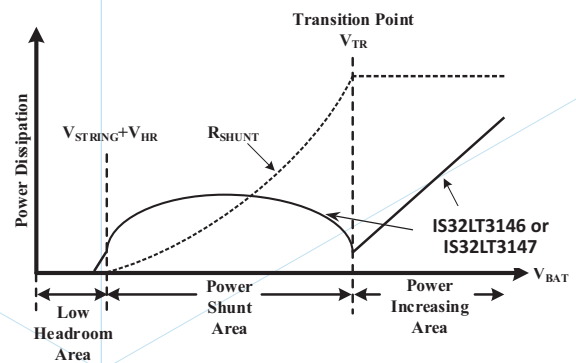

FIGURE 2 - POWER DISSIPATION VS V_{BAT}

In terms of system reliability, both drivers feature undervoltage-lockout mechanism to prevent device mis-operation at supply voltages that is too low; and integrates detection circuitry for various faults with reporting to FAULTB pin. Faults detected and reported include LED string open/shorted, single LED shorted, ISET pin open/shorted, and thermal shutdown. Further, if driver’s junction temperature exceeds 150°C, built-in thermal roll-off feature will automatically decrease output channel current at 3.7%/°C until thermal shutdown. This thermal roll-off is not reported to FAULTB pin but protects the device from damage. An appropriate voltage at UV input pin sets the undervoltage fault reporting threshold and a fixed value resistor to ground at FMODE input pin sets “one-fail-all-fail” or “one-fail-other-on” modes; and in each case, the option for “retry current in faulty channel”.

IS32LT3146 SPECIFIC FEATURES

The IS32LT3146 provides additional logic to turn on output channels in groups of 1, 2, 3 or 6 in one-group-after-another-group sequential mode or all-channels blinking on/off mode. The grouping of multiple output channels enables adaptation for LEDs with higher current demands. The sequential turn on of channels startup and interval timing are setup via resistors at STDEL and INTDEL input pins. The IS32LT3146 was designed for standalone solution where a vehicle’s BCM (Body Control Module) signal powers the device and all functions can be configured via external resistors without the need of a microcontroller host. Multiple IS32LT3146 instances can be synchronized with or without signaling connection. Figure 3 illustrates synchronization by connecting all SEQEN pins of all instances and cascade connections from SEQOUT of one device to next device’s EN pin.

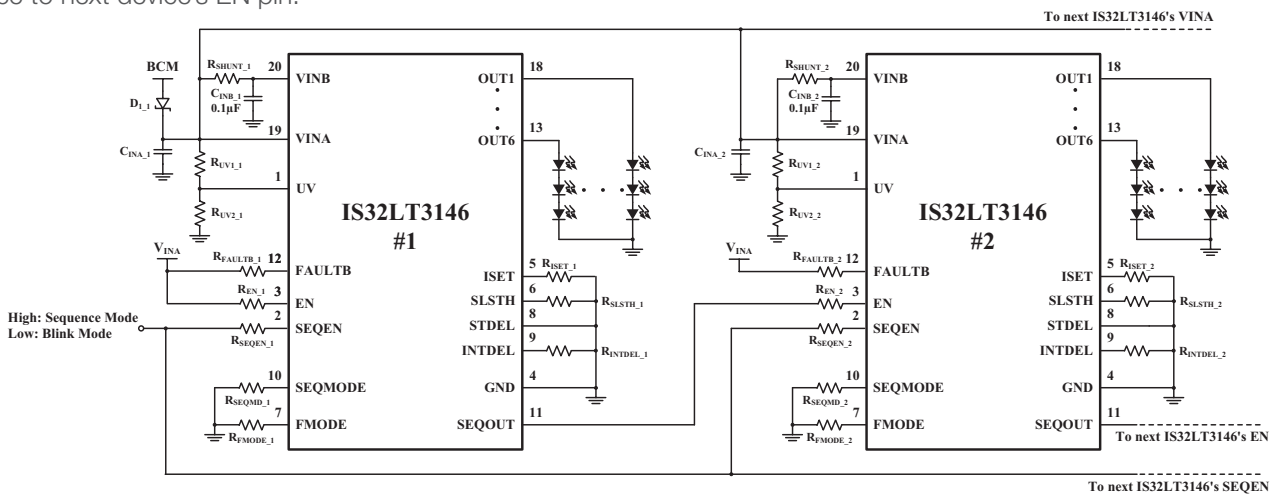

FIGURE 3 - SYNCHRONIZING IS32LT3146’S BY COMMON BCM POWER ‘SEQEN’ AND ‘SEQOUT TO EN’ CONNECTIONS

Figure 4 illustrates synchronization by common BCM power and appropriate values resistors to set the startup delay at STDEL input pin of each IS32LT3146 instance. This permits device instances to be far apart or be across physical gap such as ‘A and B turn-lights’ where portion of the lighting fixture is on the trunk door and also on the vehicle’s corner as in Figure 5.

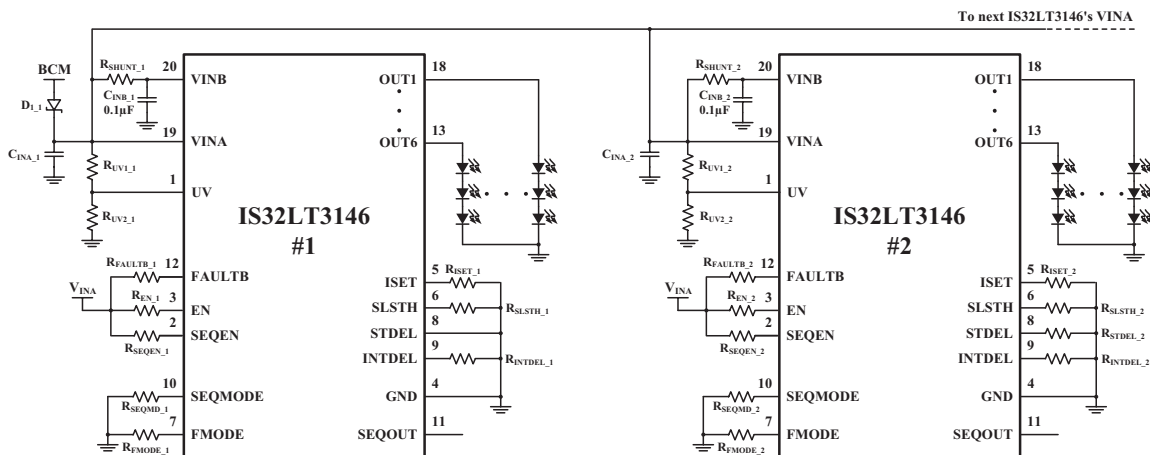

FIGURE 4 - SYNCHRONIZING IS32LT3146’S BY COMMON BCM POWER AND APPROPRIATE VALUED RESISTOR AT STDEL



FIGURE 5 - A AND B TURN-LIGHT

IS32LT3147 SPECIFIC FEATURES

The IS32LT3147 output channels have individual PWM dimming via dedicated PWM input control pins. An off-the-shelf microcontroller host with sufficient GPIO pins could generate PWM control signals. Alternatively, Lumissil's IS32LT3134 animation controller could be used to connect up to two IS32LT3147 devices and modulate up to 12 output current sources for complex lighting patterns.

If PWM dimming is not required, IS32LT3147 could be powered by vehicle's BCM power with its PWM input control pins pulled high or low to enable or disable each channel respectively.

APPLICATIONS OF IS32LT3146 AND IS32LT3147

Both drivers are suited for Automotive interior or exterior lighting. IS32LT3147 has the additional benefit of dimming control of each channel's LED string or generate complex light animations when used with IS32LT3134 animation controller. Figure 6 illustrates single IS32LT3134 with 2 IS32LT3147. IS32LT3146 has state machine logic for turning on each group of channel(s) sequentially one after another with adjustable timing or simply all channels blinking on and off also with adjustable timing.

[Click here to view the video](#) that illustrates sequential turn-on in vehicle front and rear end lights.

[Click here to view the video](#) that illustrates blinking on and off in a vehicle rear-end light.

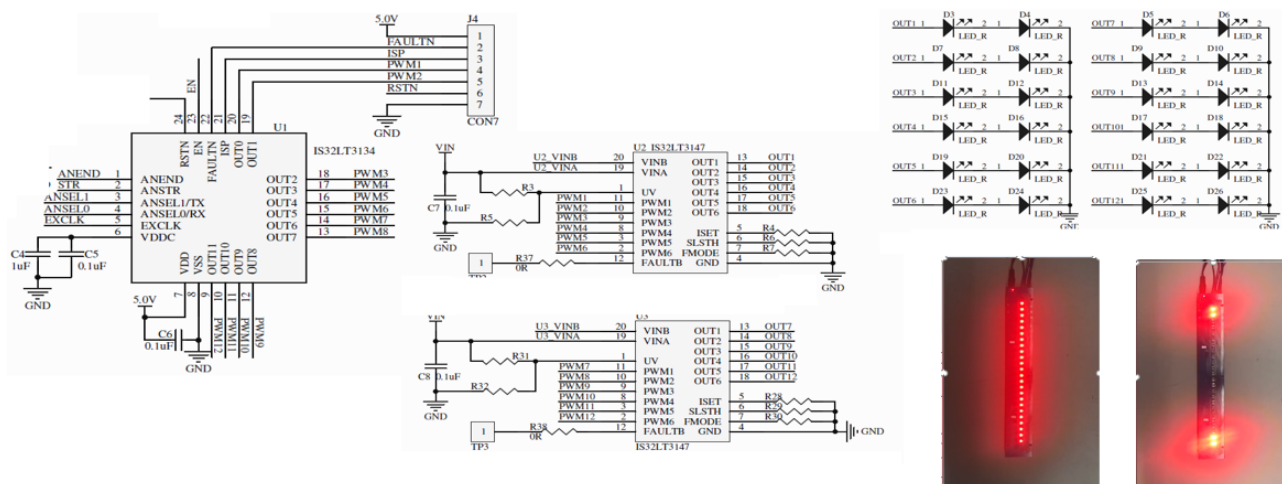

FIGURE 6 - IS32LT3134 ANIMATION CONTROLLER WITH 2 IS32LT3147 FOR COMPLEX LIGHTING PATTERN PLAYBACK

Both drivers could be applied for general interior lighting, accent lighting and welcome lighting; with IS32LT3146 having the ability for sequential or blinking turn on capability and IS32LT3147 with PWM dimming control per LED string.



FIGURE 7 - GENERAL INTERIOR LIGHTING (LEFT) AND WELCOME LIGHTING (RIGHT)

PRODUCT ORDERING AND AVAILABILITY

Lumissil ordering part numbers:

Part Number	Package	Quantity
IS32LT3146-ZLA3-TR	eTSSOP-20, Lead-free	2500 per reel
IS32LT3147-ZLA3-TR	eTSSOP-20, Lead-free	2500 per reel

IS32LT3146 and IS32LT3147 are sampling now. Enquire with your Lumissil Sales Representative to order samples and evaluation boards.

Lumissil Team is committed to provide customers strong technical support and abide to ISSI company's mission to maintain long-term support.

CONTACT:

Questions or feedback may be sent to:

Allan Chan

Lumissil Microsystems Marketing Products Manager

allan_chan@lumissil.com